

RadioLink D460

Instruction Manual

使用说明书



14+

D460(RTF) Contents

Disclaimer and Warning	3
Packing List	4
Chapter 1 D460 General Introduction	5
1.1 D460 Overview	5
1.2 Usage of D460 Units	6
1.2.1 Notice for Use	6
1.2.2 Transmitter & Receiver	6
1.2.3 Flight Controller Byme-DB	7
1.2.4 Motor	7
1.2.5 ESC	8
1.2.6 Servo	8
1.2.7 Propeller	8
1.2.8 Battery	8
1.2.9 Charger	9
Chapter 2 Flight Modes Setup	10
Chapter 3 Motor Safety Lock	11
Chapter 4 Transmitter Setup	11
Chapter 5 Flight Precautions	12
Chapter 6 Power-on and Gyro Self-test	12
Chapter 7 Attitude Calibration	12
Chapter 8 Servo Phase	13
8.1 Servo Phase Test	13
8.2 Servo Phase Adjustment	13
Chapter 9 Three Flight Modes	14
9.1 Stabilize Mode	14
9.2 Gyro Mode	16
9.3 Manual Mode	16
Chapter 10 Gyro Sensitivity	16

There are 2 versions of D460, including RTF version and PNP version.

Please refer to page 3-16 of this manual for RTF version, and page 17-22 for PNP version.

D460(PNP) Contents

Disclaimer and Warning.....	17
Packing List.....	17
Chapter 1 D460 General Introduction	17
1.1 D460 Overview and Usage of Units	17
1.2 Receiver Connection	17
Chapter 2 Flight Modes Setup	18
Chapter 3 Motor Safety Lock	18
Chapter 4 Transmitter Setup	19
4. 1 Model Type Setup	19
4. 2 Transmitter Phase Setup	20
Chapter 5 Flight Precautions	20
Chapter 6 Power-on and Gyro Self-test.....	20
Chapter 7 Attitude Calibration	20
Chapter 8 Servo Phase	22
Chapter 9 Three Flight Modes	22
Chapter 10 Gyro Sensitivity	22

Disclaimer and Warning

Thank you for purchasing RadioLink fixed wing D460.

To fully enjoy the benefits of this product and ensure safety, please read the manual carefully and set up the device as instructed steps. This product is not a toy and is NOT suitable for children under the age of 14. Adults should keep the product out of the reach of children and exercise caution when operating this product in the presence of children.

Inappropriate operation may causes property loss or accidental threats to life. Once the RadioLink product is operated, it means the operator understands this limitation of liability and accepts to take responsibility of the operation.

Make sure to follow the local laws and agree to follow the principles that made by RadioLink.

Fully understand that RadioLink cannot analyze the product damage or accident reason and cannot offer after-sales service if no flight record is provided. To the maximum extent permitted by law, RadioLink won't take any responsibility about the loss caused by indirect/consequent/accidental/special/penal damages including the loss by purchase, operation and failure of operation in any instances. Even RadioLink is informed about the possible loss in advance.

Laws in certain countries may prohibit the exemption from the terms of the guarantee. Therefore consumer rights in different countries may vary.

In compliance with laws and regulations, RadioLink reserves the right to interpret the above terms and conditions. RadioLink reserves the right to update, change or terminate these terms without prior notice.

Warning

1. Please do not fly in the rain! Rain or moisture may cause flight instability or even loss of control. Never fly if there is lightning. It is recommended to fly in conditions with good weather (No rain, fog, lightning, wind).
2. When flying, you must strictly abide by local laws and regulations and fly safely! Do not fly in no-fly areas such as airports, military bases, etc.
3. Please fly in an open field away from crowds and buildings.
4. Do not perform any operation under the condition of drinking, fatigue or other poor mental state. Please operate in strict accordance with the product manual.
5. Please be cautious when flying near electromagnetic interference sources, including but not limited to: high-voltage power lines, high-voltage transmission stations, mobile phone base stations and TV broadcast signal towers. When flying in the above-mentioned places, the wireless transmission performance of the remote control may be affected by interference. If there is too much interference, the signal transmission of the remote control and the receiver may be interrupted, resulting in a crash.

Packing List

Items	Details	Picture	PNP	RTF
Fuselage	Expanded Polypropylene (EPP), 480mm wingspan, 430mm length, 155g weight, two colors available ¹		1	1
Transmitter	RadioLink T8S ²		0	1
Receiver	RadioLink R8XM		0	1
Flight Controller	RadioLink Byme-DB		1	1
Battery	2S 7.4V 800mAh lithium battery		1	1
Motor	SZ-SPEED 2204HA1-1600KV brushless motor		1	1
ESC	FLYCOLOR 15A brushless ESC		1	1
Propeller	GEMFAN 7052 propellers, dia.177.8mm (with one rubber fix band)		2	2
Servo	4.3g servos		2	2
Charger	RadioLink balance charger CM210 for 2S LiPo Battery		0	1
Other Accessories	2.0 cross screwdriver		1	1
	Charging&update cable for T8S		0	1
	Spare Rudder Angle		1	1
	Spare fber tape		1	1
	Instruction manual		1	1
Packaging (Choose one)	Hand-held backpack		1	1
	Colorful box			

Annotation¹: D460 fuselage is available in red and purple. Please refer to the sales interface for the actual color of your D460.

Annotation²: T8S is used as an example in D460 manual. Users can choose other RadioLink transmitters and receivers to control D460. Optional RadioLink transmitters include T8S, T8FB, T16D, AT9S Pro, and AT10II.

Note: Please refer to the sales interface for the actual packing list.

Chapter 1 D460 General Introduction

1.1 D460 Overview

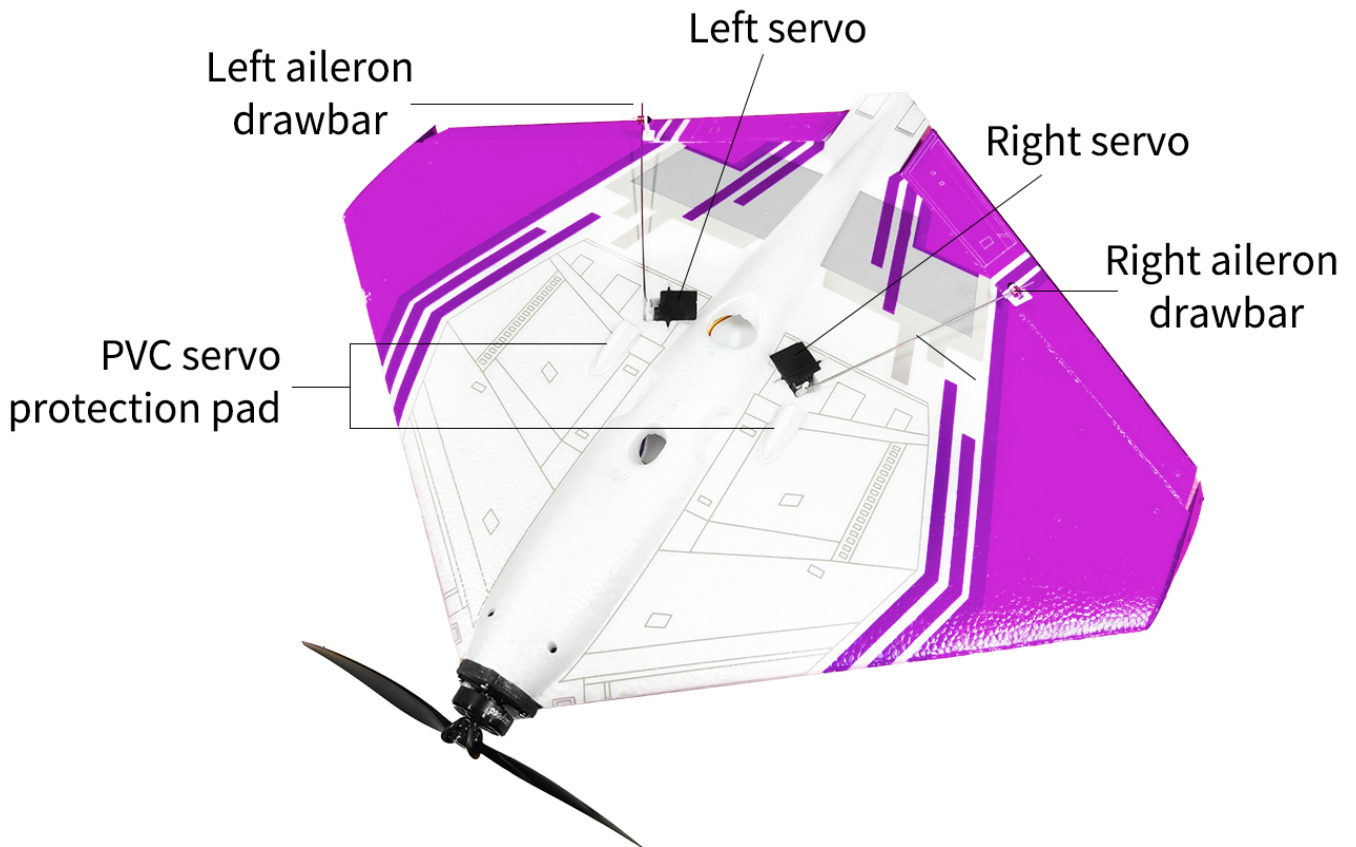
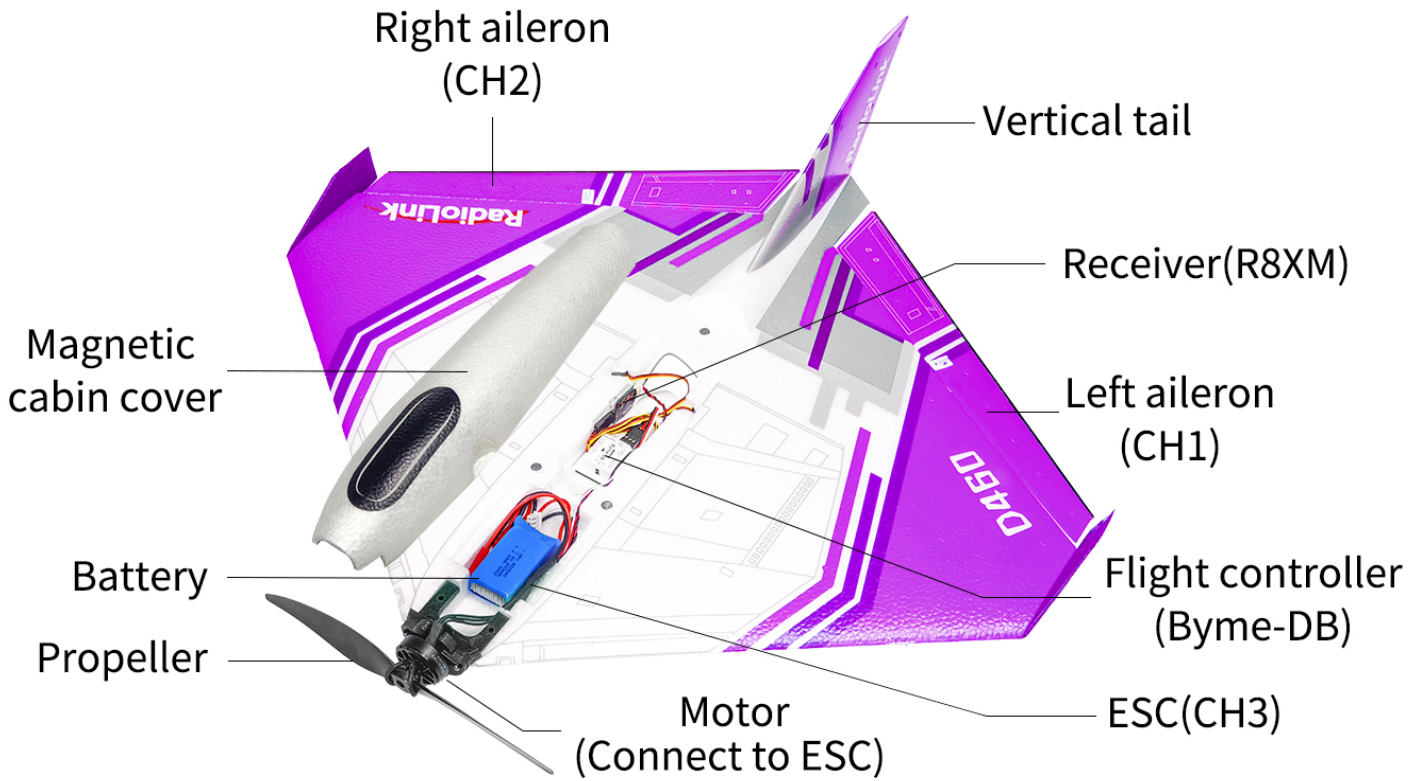

1.2 Usage of D460 Units

1.2.1 Notice for Use

No foreign matter such as water, oil, sand etc. inside the D460.

Make sure the complete device incl. D460 and transmitter, battery functions well.

Never self-change the aircraft or related parts. Or it may influence its functionality and possibly cause flight accident.

1.2.2 Transmitter & Receiver

D460 RTF(Ready To Fly) is packed with RadioLink 8-channel transmitter T8S (or T8FB) and mini receiver R8XM, with the stable control distance up to 4000 meters and real-time built-in telemetry function. (Maximum range tested in unobstructed areas free of interference and may vary depending on local regulations.)

If it is the PNP version purchased, please refer to the manuals of the transmitter and receiver used for more details.

Joystick Mode

To beginners, it's very important to understand what joysticks connect to different channels and choose the most suitable mode .

First, throttle is controlled by toggling joystick up(top-max 100%) and down (bottom-min 0%). Below explanation takes MODE 2 with throttle joystick on left as example.

Left Joystick: Toggle up and down to control the motor (up as accelerate while down as decelerate). Toggle left and right, there is no movement of the control surfaces of D460.

Right Joystick: Toggle up and down to control the elevator mix of D460. Toggle left and right to control the aileron mix of D460.



Usage of T8S Transmitter:

- Make sure the transmitter power is fully charged. The battery level can be judged based on the LED indicators on T8S. One LED light represents 25% of the power. All four LED power indicators are on means T8S is fully charged.
- If transmitter is changed, binding process needs to be redone before use. Please refer to the user manual of T8S for more details. You can visit RadioLink official website for detailed user manual of T8S: https://www.radiolink.com/t8s_manual
- Make sure to power off the D460 before the transmitter when landing.

The standard packed receiver of D460, R8XM supports real-time transmission of RSSI, receiver voltage, and model voltage. The telemetry range is the same as the control range, 4000 meters. R8XM supports up to 6S (25.2V) battery voltage telemetry. For the connection of R8XM and all the other devices, please refer to Chapter 1.2.3 Flight Controller By-me-DB.

When the returned RSSI, receiver voltage, and model voltage are lower than the set alarm value, the transmitter will emit alarm tone:

- 1) Low transmitter voltage alarm: keep DDDD beep quickly and continuously. T8S has a built-in battery. The alarm battery voltage defaults to 3.7V, and it cannot be modified.
- 2) Low model voltage alarm: three DDD beeps as a unit continuous beeping prompt.
- 3) Low RSSI alarm: four DDDD beeps as a unit continuous beeping prompt.
- 4) Low receiver voltage alarm: five DDDDD beeps as a unit continuous beeping prompt.

The returned model voltage alarm is set to 7.4V (2S battery) by default. When the battery voltage of D460 is lower than 7.4V, the transmitter will emit three DDD beeps to alarm.

For detailed manual of R8XM receiver, please check it on RadioLink official website:

https://www.radiolink.com/r8xm_manual

1.2.3 Flight Controller Byme-DB

D460 RTF version is installed with flight controller Byme-DB by default. When installing or replacing the flight controller, make sure the arrow on Byme-DB points to the aircraft head. Use 3M glue to flatly attach Byme-DB to the fuselage. It is recommended to install it near the center of gravity of the aircraft. If the flight controller is not installed stably, the aircraft will vibrate abnormally when flying in stabilize and gyro modes. Refer to the picture below to connect the flight controller, servos, receiver, ESC, motor and battery.

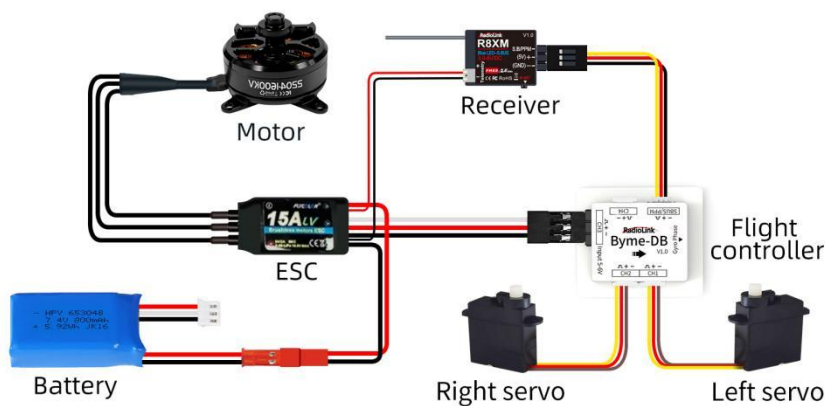

Channel (CH)	Meaning
CH1	Aileron mix. Connect to left servo
CH2	Elevator mix. Connect to right servo
CH3	Throttle. Connect to ESC
SBUS/PPM	SBUS/PPM signal. Connect to receiver

1.2.4 Motor

Motor installed on D460 is SZ-SPEED 2204HA1-1600KV brushless motor. (Motor with higher KV value, means higher rotation speed and smaller torsion force; Motor with lower KV value, means lower rotation speed and larger torsion force.)

Usage of Motor:

1. Make sure the motor is installed tightly and rotate smoothly. If fail to rotate, stop operating transmitter immediately and pull the throttle to the bottom position in case of possible damage to motor.
2. Never self-change the motor structure.
3. When motor stops rotating, never touch it at once, otherwise may get burnt.
4. Never cover the air vent on the motor. Make sure no foreign matter inside the motor.
5. Make sure motor completely stops before powering off the D460 and the transmitter.

1.2.5 ESC

The function of ESC is to change the direct current to alternating one to power supply motor and change its rotation speed basing on the throttle command. Another function of ESC is to lower the model voltage to 5V for receiver as the battery applied for D460 supports 7.4V-8.4V working voltage. Therefore, there are three wires of ESC respectively for battery, motor and receiver. ESC applied in D460 is 15A brushless ESC.

Usage of ESC:

Make sure there's a tone from ESC when power on the aircraft.

1.2.6 Servo

D460 uses 4.3g servos and two servos are installed on the left and right sides of the fuselage.

1.2.7 Propeller

D460 is packed with 2 positive propellers by factory default. If new propeller needs to be changed, you need to distinguish the front and back side of the propeller. If the front and back side of the propeller are installed incorrectly, the aircraft couldn't take off even maximize the throttle. The propeller with words should face the nose of D460. The rotation direction of motor and propeller should be the same. That is, if the motor rotates clockwise, so does the propeller.

Usage of propeller:

1. Make sure to check the propeller is in good condition before flight. If aged, damaged or deformed, please change to good one then flight.
2. Make sure to disconnect the power supply before touching the propeller.
3. As propeller is thin, use tools to (un)install if necessary and be careful to avoid accidental scratch.
4. Make sure propeller is installed well and tight before flight.
5. Do not get close to rotating propeller and motor (for example, to pick up a landing plane by hand) to avoid cuts.

1.2.8 Battery

D460 supports 2S-3S LiPo battery. D460 is packed with 2S 7.4V 800mAh LiPo Battery.

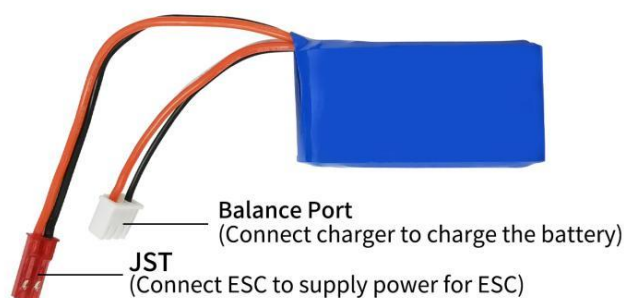

Usage of battery:

1. Make sure the power connection of transmitter and aircraft is dry.
2. Make sure the transmitter and aircraft are fully charged.
3. When the transmitter emits DDD beeps to alarm low battery voltage, if the power of the aircraft drops when the throttle is pushed, the battery voltage on the aircraft is insufficient. At this time, please return to the flight immediately to avoid the failure of the aircraft to return due to the insufficient power battery voltage and the over-discharge of the battery.

1.2.9 Charger

D460 is packed with RadioLink CM210 balance charger (Only for 2S lipo battery) to charge the battery.

CM210 Specifications:

Size: 40.5*21*15 mm

Weight: 9g

Input Voltage: 5V

Supporting Battery: 2S LiPo battery

Charging Precision: 0.02V

Charging Voltage: Max. 4.2V for each battery cell

Charging Current: 1.5A

Balance Current: 0.8A

Max. Output Power: 20W

Power Supply Input Port: USB Type-C Input

Charging Port Interface: 3P XH2.54 port

Working Modes: Charging Mode, Balance Mode, Repair Mode (Self-adaptive, with no need to set it)

The connection of CM210, battery, cable is as shown below:

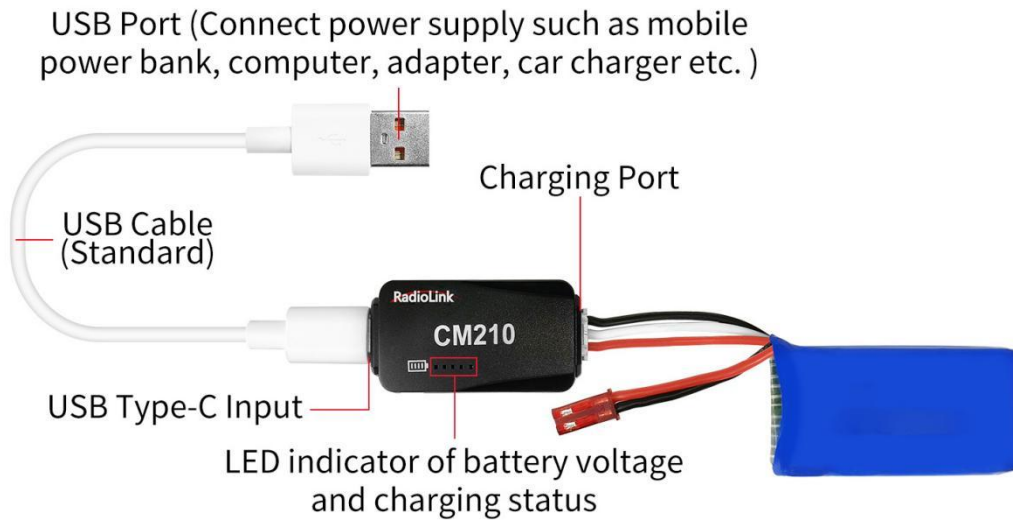

Instructions for using CM210 charger:

1. Insert one end of the standard USB cable into the Type-C input port of the CM210 charger (as shown in the picture above), and then connect the other end of the USB cable to power supply equipment such as power bank, computer, mobile phone adapter, etc.. After the right connection, the red LED indicator will be always on.
2. Insert the balance port of the standard 2S lithium battery of D460 into the charging port of CM210 (as shown in the picture above). Then the green LED indicator starts flashing, which means it starts to charge the battery. (Note: The green LED indicator flashes during the charging to indicate normal charging; If the red LED indicator flashes during the charging to indicate abnormal charging. Please reconnect battery and cable to troubleshoot the abnormality.)
3. When all four LED indicators turn solid green, the battery is fully charged, and the charger will automatically stop charging.
4. Remove the battery and then disconnect the power supply.

CM210 LED indicator status:

LED color	Status	Meaning
Red	Flash	The charger detects abnormality.
	Always on	No battery is connected.
Green	All four green LEDs flash once.	The charger is powered on.
	The first green LED flashes, and the other LEDs are off.	The battery voltage is lower than 7.4V.
	The first green LED is always on, and the second green LED is flashing. The other LEDs are off.	The battery voltage is lower than 7.8V.

The front two green LEDs are always on, and the third green LED is flashing. The other LEDs are off.	The battery voltage is lower than 8.2V.
The front three green LEDs are always on, and the fourth green LED is flashing. The other LED is off.	The battery voltage is lower than 8.4V.
All four green LEDs are always on.	The battery is fully charged.

Troubleshooting for CM210 charger:

- After the charger is powered on, the red light flashes just after inserting the battery or within one minute.
 - The current detection resistor is burned out, and the MCU detects that the current is too large.
 - The switch tube is damaged, so it is unable to switch normally. There is no current output or the output current of the power supply is too small.
 - After the charger is powered on, insert the battery and charging works normally for a period of time, and then the red light flashes.
 - The output current of the power supply is too small, or the battery is damaged.
- Solution: Replace the power supply or battery to charge it again, if the abnormal phenomenon still occurs, the charger is damaged.

Chapter 2 Flight Modes Setup

Flight modes of D460 can be set channel 5 (CH5) (a 3 way switch) in the transmitter with 3 modes: Stabilize Mode, Gyro Mode and Manual Mode. Flight modes of D460 are set by CH5 of T8S by default, as follows.

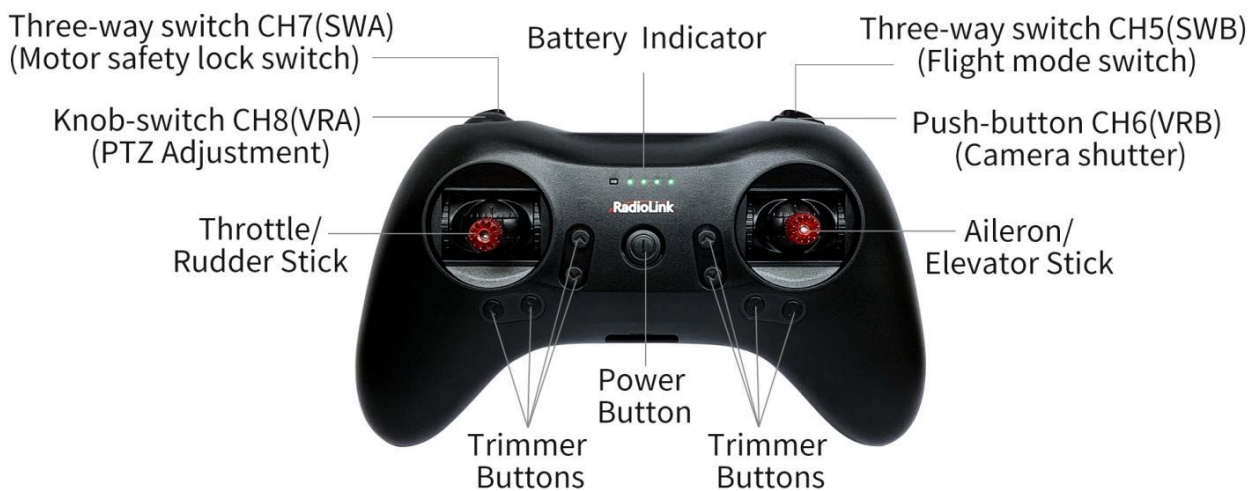
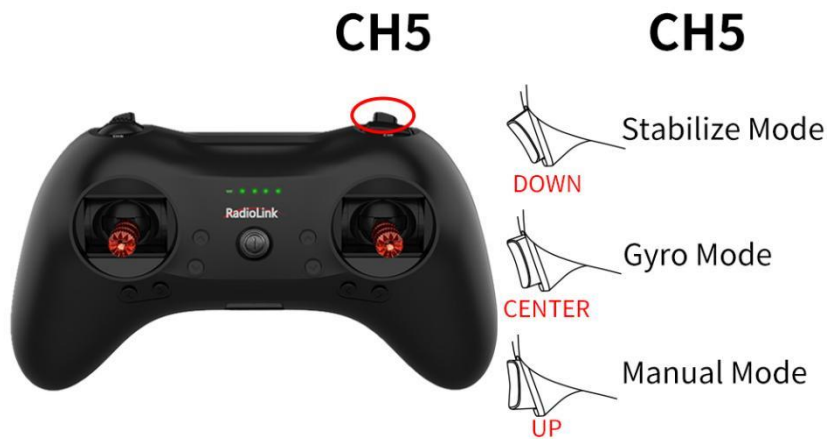

Mode 2

Chapter 3 Motor Safety Lock

The motor can be locked/unlocked by Channel 7 (CH7) in the transmitter.

When the motor is locked, the motor will not rotate even if the throttle stick is in the highest position. Please put the throttle to the lowest position, and toggle the switch of channel 7 (CH7) to unlock the motor. The motor emits two long beeps means the unlocking is successful. When the motor is locked, the gyro of Byme-DB is automatically turned off; When the motor is unlocked, the gyro of Byme-DB is automatically turned on.

Note: If the motor only beeps once when toggle the switch of channel 7 to the unlock position, the unlocking fails. Please check whether the throttle is at the lowest position. If not, please push the throttle to the lowest position until the motor emits a second long beep, which means the unlocking is successful.

The motor lock of D460 are controlled by CH7 of T8S by default, as follows.



Chapter 4 Transmitter Setup

The transmitter phase of T8S transmitter has already been set up, but please check it again before taking off. Please check the transmitter phase in T8S Parameter Setup APP. Enter the basic menu. Set CH1/CH2/CH4 to NORM, and CH3 to REV, as shown below:

Disconnect		READ		WRITE		STORE		LOAD	
SERVO	BASIC	ADVANCED	PROG.MIX	TX: 3.0V	RX: 0.0V	EXT: 0.0V	RSSI: null		
	-CH-	-REV-	-SUB-	-EPA-L	-EPA-R	-F/S-	DELAY		
	CH1:	NORM	0	96	96	50	100		
	CH2:	NORM	0	96	96	50	100		
	CH3:	REV	0	96	96	0	100		
	CH4:	NORM	0	96	96	50	100		
	CH5:	NORM	0	96	96	50	100		
	CH6:	NORM	0	96	96	50	100		
	CH7:	NORM	0	96	96	50	100		
	CH8:	NORM	0	96	96	50	100		

Click https://www.radiolink.com/t8s_apps to download T8S Parameter Setup APP for Android mobile phone.

For Apple mobile phone, please search for "T8S" in App Store to download T8S Parameter Setup APP.

Please click https://www.radiolink.com/t8s_manual to download the detailed manual of T8S in RadioLink official website.

Note: Do not set any mixing in the transmitter when Byme-DB is mounted on the aircraft. Because there is already the mixing in Byme-DB. The mix control will automatically take effects according to the flight mode of the aircraft. If the mixing function is set in the transmitter, there will be conflicts of mixing and affect the flight.

Chapter 5 Flight Precautions

1. Check before take-off to make sure that all parts are in good working condition.
2. Make sure the battery is fully charged and properly bound to the fuselage before take-off.
3. Make sure that the front and back of the propeller are installed correctly and the propeller is not inclined.
4. After the setting of channel direction in the transmitter, please calibrate the attitude once. Then check the servo phase. Push the joystick to check whether the movement of the control surface is correct. If it is not, please change the direction of the corresponding channel on the flight controller.
5. After the motor is unlocked, the gyro function is automatically turned on. Hold the D460 in your hand and swing it, without operating the joystick of the transmitter. If there is no movement on the control surface, it is in manual mode. If the control surfaces move as the fuselage swings, it is stabilize mode or gyro mode.
6. It is recommended to change another battery to avoid over-discharge of the battery when the transmitter emits DDD beeps to alarm low battery voltage.
7. If there is any abnormality during the flight, please land immediately and find out the reason.

Chapter 6 Power-on and Gyro Self-test

Each time D460 is powered on, the gyro of the flight controller will perform self-test. The gyro self-test can only be complete when the aircraft is stationary. It is recommended to install the battery first, then power up the aircraft and keep the aircraft in a stationary state. After the aircraft is powered on, the green indicator light on channel 3 will be always on. When the gyro self-test passes, the control surfaces of the aircraft will shake slightly, and the green indicator lights of other channels such as channel 1 or channel 2 will also turn solid.

Note: Push the throttle stick of the transmitter to the lowest position first, and then power on the aircraft. If the throttle stick is pushed to the highest position and then power on the aircraft, the ESC will enter the calibration mode.

Chapter 7 Attitude Calibration

Flight controller Byme-DB needs to calibrate the attitudes/level to ensure the balance status.

The aircraft can be placed flat on the ground when performing attitude calibration. It is advised to lift the model head with a certain angle (20 degree is advised) for beginner to ensure smooth flight and attitude calibration will be recorded by flight controller once the it is complete with success.



Push the left stick (left and down) and the right stick (right and down) as below and hold more than 3 seconds. The green LED flashes once mean the calibration completed.



Chapter 8 Servo Phase

8.1 Servo Phase Test

Please complete the attitude calibration in Chapter 7 first. And then test the servo phase. Otherwise, the control surface may swing abnormally.

Toggle the switch of CH5 to **Manual mode**. Then check if the the movement direction of the ailerons is consistent with the joystick movement. Take Mode 2 for transmitter as an example.



Move the aileron stick to the left

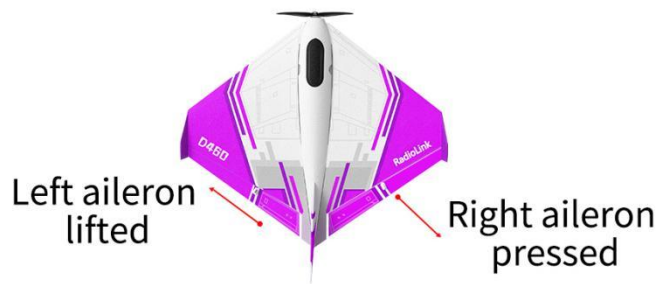

Left aileron lifted

Right aileron pressed



Move the elevator stick down

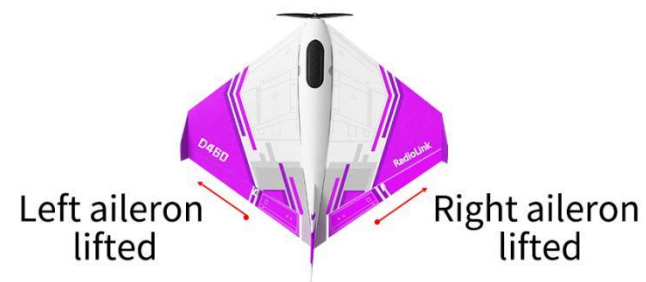

Left aileron lifted

Right aileron lifted

8.2 Servo Phase Adjustment

When the movement direction of the ailerons is inconsistent with the joystick movement, please adjust the servo phase by pressing the buttons on the front of the Byme-DB.

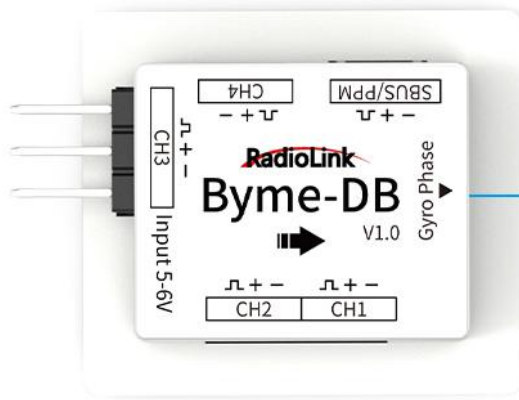

Button to change FC servo phase

Servo phase adjustment methods:

Servo phase test result	Reason	Solution	LED
Move the aileron stick to the left, the movement direction of the ailerons is reversed	Aileron mix control reversed	Short press the button once	Green LED of CH1 on/off
Move the elevator stick down, the movement direction of the ailerons is reversed	Elevator mix control reversed	Short press the button twice	Green LED of CH2 on/off
Move the rudder joystick, the movement direction of rudder servo is reversed	Channel 4 reversed	Short press the button four times	Green LED of CH4 on/off

Note:

1. Green LED of CH3 is always on.
2. Neither the always-on nor off green LED means reversed phase. Only toggle the joysticks can check if the corresponding servo phases are reversed. If the servo phase of the flight controller is reversed, adjust the servo phase by pressing the buttons on the flight controller. No need to adjust it in the transmitter.

Chapter 9 Three Flight Modes

Flight modes can be set channel 5 (CH5) in the transmitter with 3 modes: Stabilize Mode, Gyro Mode and Manual Mode. Here is the introduction of the three flight modes. Take Mode 2 for transmitter as examples.

9.1 Stabilize Mode

Stabilize Mode with flight controller balancing, is suitable for beginners to practice level flight.

The model attitude (inclination angles) is controlled by joysticks. When the joystick is back to central point, the aircraft will level. The max inclination angle is 70° for rolling while that for pitching is 45°.



Move the aileron stick to the left

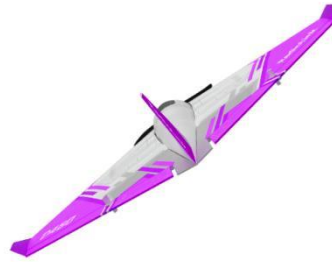

Model leans to left



Move the aileron stick to the right

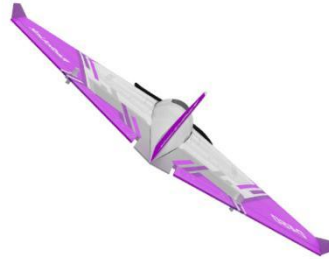

Model leans to right



Move the elevator stick down



Model nose lifts



Move the elevator stick up



Model nose pressed



Stick centered



Model levels

9.2 Gyro Mode

The joystick control the rotation (angle speed) of the aircraft. The integrated three-axis gyro assists to increase the stability.

(Gyro mode is the advanced flight mode. The aircraft won't level even the joystick is back to central point.)



Move the aileron stick to the left

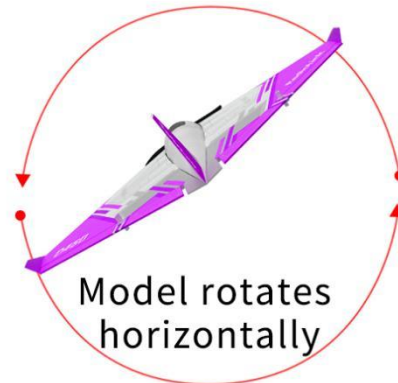

Move the elevator stick down

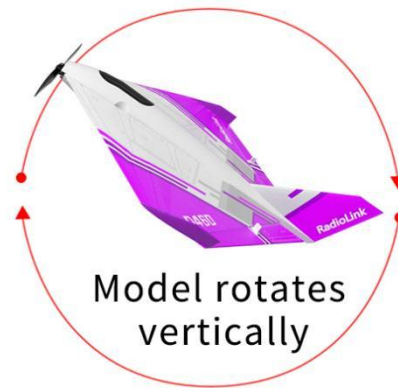

9.3 Manual Mode

No assistance from flight controller algorithm or gyro, all flight movements are realized manually, which requires the most advanced skills. In Manual mode, it is normal that there is no movement of the control surface without any operation on the transmitter because there is no gyroscope involved in stabilize mode.

Chapter 10 Gyro Sensitivity

There is certain stability margin for the PID control of Byme-DB. For aircraft or models of different sizes, if the gyro correction is insufficient or the gyro correction is too strong, pilots can try adjusting the position of the mounting hole of the servo arms to adjust the gyro sensitivity.

D460 (PNP) Instruction Manual

Disclaimer and Warning

Please refer to D460 RTF Disclaimer and Warning.

Packing List

Please refer to D460 RTF Packing List.

Chapter 1 D460 General Introduction

1.1 D460 Overview and Usage of Units

Please refer to D460 RTF Chapter 1 D460 General Introduction. (D460 PNP version does not come with transmitter, receiver, or charger. Please refer to the manuals of these products for their using methods.)

1.2 Receiver Connection

For D460 PNP version, transmitter and receiver needs to be installed. D460 is compatible to all receivers that supports SBUS/PPM signal.

1. First, install the receiver on D460 aircraft. Make sure the receiver is switched to SBUS/PPM signal mode, and then connect the receiver to Byme-DB flight controller. For the connection method of the receiver, please refer to D460 RTF Chapter 1.2.3 Flight Controller.

Note: Byme-DB comes with a receiver connect cable which is used to connect the receiver to Byme-DB. When connecting the servo cable and ESC cable to Byme-DB, please check whether the servo cable and ESC cable match the sockets/head of Byme-DB. If they do not match, the user needs to modify the servo cable and ESC cable, and then connect the cables to Byme-DB.

Byme-DB Socket Specifications: CH1, CH2 and CH4 are with 3P SH1.00 sockets; The receiver connect socket is 3P PH1.25 socket; CH3 is with a 3P 2.54mm Dupont Head

2. Second, calibrate the throttle range of D460 ESC. The normal Start-up and Throttle Range calibration steps of D460 ESC are as follows:
 - 1) Turn on the transmitter. Toggle switch of CH7 to unlock the motor, and then move the throttle stick to the top position.
 - 2) Connect battery to the ESC and wait for the motor to emit a short beep, which means the full throttle position is memorized.
 - 3) After the flight controller self-check is completed, move the throttle stick to the bottom position, and the motor will make a short beep, indicating that the "zero throttle" position is memorized.
 - 4) The ESC calibration is complete and D460 is ready to take off at any time.

For more information on how to use D460 ESC, please visit RadioLink official website:
https://www.radiolink.com/manuals_download

Chapter 2 Flight Modes Setup

Flight modes of D460 can be set channel 5 (CH5) (a 3 way switch) in the transmitter with 3 modes: Stabilize Mode, Gyro Mode and Manual Mode.

When using other brand transmitters, please refer to the following picture to switch the flight modes. The value range of channel 5 (CH5) corresponding to the flight mode is as shown below:

CH5

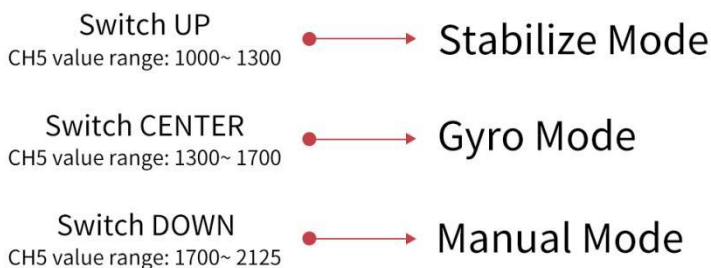

Take RadioLink AT9S Pro transmitter as example. Flight modes are set by CH5 (3-way switch, SWC) as below:



Chapter 3 Motor Safety Lock

The motor can be locked/unlocked by Channel 7 (CH7) in the transmitter, so please use the transmitter with 7 channels or above

When the motor is locked, the motor will not rotate even if the throttle stick is in the highest position. Please put the throttle to the lowest position, and toggle the switch of channel 7 (CH7) to unlock the motor. The motor emits two long beeps means the unlocking is successful. When the motor is locked, the gyro of Byme-DB is automatically turned off; When the motor is unlocked, the gyro of Byme-DB is automatically turned on.

Note: If the motor only beeps once when toggle the switch of channel 7 (CH7) to the unlock position, the unlocking fails. Please follow the methods below to troubleshoot it.

1. Check whether the throttle is at the lowest position. If not, please push the throttle to the lowest position until the motor emits a second long beep, which means the unlocking is successful.
2. Since the PWM value width of each transmitter may be different, when using other transmitters except RadioLink T8FB/T8S, if the unlocking still fails even though the throttle is at the lowest position, you need to increase the throttle travel in the transmitter. You can toggle the switch of channel 7 (CH7) to the motor

unlocking position, and then adjust the throttle travel from 100 to 101, 102, 103... until you hear the second long beep from the motor, which means the unlocking is successful. During the process of adjusting the throttle travel, be sure to stabilize the fuselage to avoid injuries caused by propeller rotation.

When using other brand transmitters, please refer to the following picture to locked/unlock the motor. The value range of channel 7 (CH7) is as shown below:

CH7

Switch UP → Motor Unlocked
CH7 value range: 1000~ 1300

Switch DOWN → Motor Locked
CH7 value range: 1700~ 2125

Take RadioLink AT9S Pro transmitter as example. Motor lock is controlled by CH7 (2-way switch, SWD) as below:



Chapter 4 Transmitter Setup

4. 1 Model Type Setup

For D460 PNP version, model type needs to be set as fixed wing in the transmitter. Take AT9S Pro as example(same as AT10II/AT9S/AT10/AT9).

Steps: Power on the transmitter - Long press Mode to enter BASIC MENU - Turn the Dial to MODEL TYPE - Press Push to enter the menu and turn Dial to select ACROBASIC - Long press Push for 1 second and a notice “ARE YOU SURE” pops out - Press Push again and a notice” Please wait...” pops out and there will be DEE sound heard, meaning setting complete.

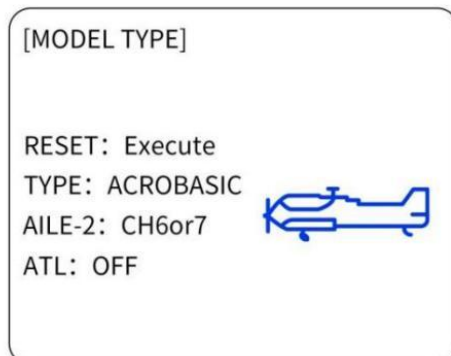

4.2 Transmitter Phase Setup

When using a non-RadioLink transmitter, there is no need to set the transmitter phase.

Please set the direction of CH3 to Reverse, and other channels CH1/CH2/CH4 to Normal. Take AT9S Pro as an example (same as AT10II/AT9S/AT10/AT9).

Steps: Long press Mode to enter BASIC MENU - rotate Dial to REVERSE - Press Push to enter the menu - rotate Dial to 3:THRO - change NOR to REV - Long press Push for 1 second to confirm.

[REVERSE]		
	1: AILE	NOR
	2: EIEV	NOR
CH3: THRO	→3: THRO	REV
REV	4: RUDD	NOR
CH9: NOR	5: GEAR	NOR
CH10: NOR	6: FLAP	NOR
CH11: NOR	7: AUX1	NOR
CH12: NOR	8: AUX2	NOR

Note: Do not set any mixing in the transmitter when Byme-DB is mounted on the aircraft. Because there is already the mixing in Byme-DB. The mix control will automatically take effects according to the flight mode of the aircraft. If the mixing function is set in the transmitter, there will be conflicts of mixing and affect the flight.

Chapter 5 Flight Precautions

Please refer to D460 RTF Chapter 5 Flight Precautions.

Chapter 6 Power-on and Gyro Self-test

Each time D460 is powered on, the gyro of the flight controller will perform self-test. The gyro self-test can only be complete when the aircraft is stationary. It is recommended to install the battery first, then power up the aircraft and keep the aircraft in a stationary state. After the aircraft is powered on, the green indicator light on channel 3 will be always on. When the gyro self-test passes, the control surfaces of the aircraft will shake slightly, and the green indicator lights of other channels such as channel 1 or channel 2 will also turn solid.

Note:

1. Due to differences in aircraft, transmitters and other equipment, it is possible that the green indicators of other channels (such as channel 1 and channel 2) will not be on after the gyro self-test of Byme-DB is complete. Please judge whether the self-test is complete by checking whether the control surfaces of the aircraft shake slightly.
2. Push the throttle stick of the transmitter to the lowest position first, and then power on the aircraft. If the throttle stick is pushed to the highest position and then power on the aircraft, the ESC will enter the calibration mode.

Chapter 7 Attitude Calibration

Flight controller Byme-DB needs to calibrate the attitudes/level to ensure the balance status.

The aircraft can be placed flat on the ground when performing attitude calibration. It is advised to lift the model head with a certain angle (20 degree is advised) for beginner to ensure smooth flight and attitude calibration will be recorded by flight controller once the it is complete with success.

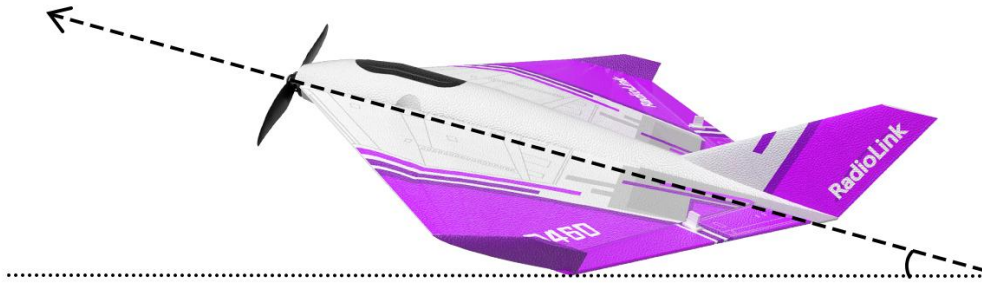

Push the left stick (left and down) and the right stick (right and down) as below and hold more than 3 seconds. The green LED flashes once mean the calibration completed.

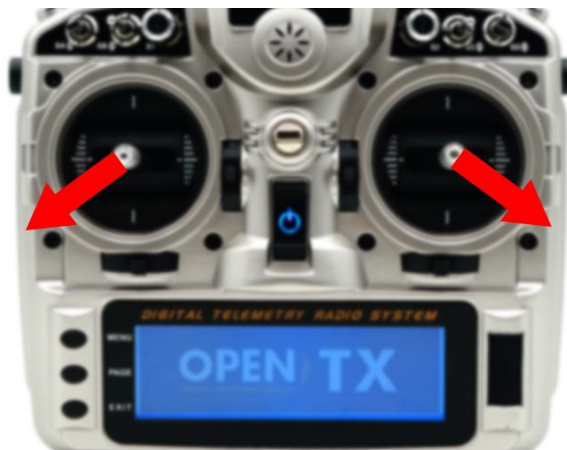

Note: When using a non-RadioLink transmitter, if the attitude calibration is unsuccessful when pushing the left stick (left and down) and the right stick (right and down), please change the direction of the channel in the transmitter. Make sure when pushing the joystick as above, the value range of channel 1 to channel 4 is: CH1 2000 μ s, CH2 2000 μ s, CH3 1000 μ s, CH4 1000 μ s

Take an open source transmitter as example. The servo display of channel 1 to channel 4 when calibrating the attitude successfully is as shown below:

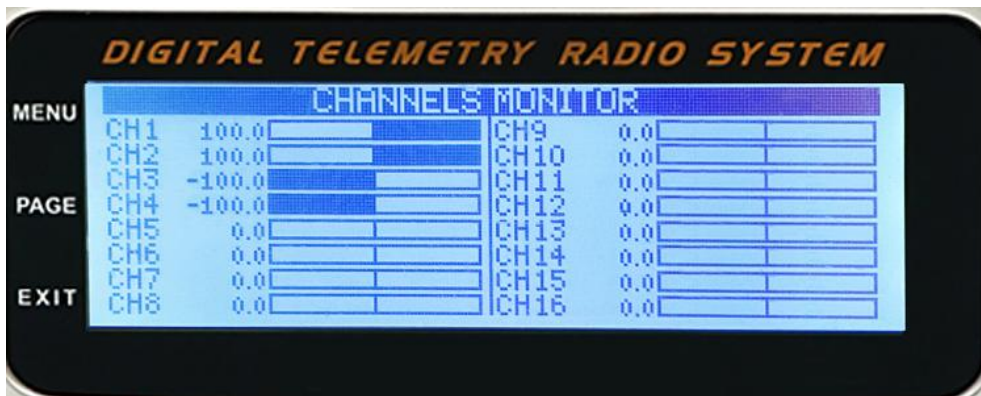

CH1 2000 μ s (opentx +100), CH2 2000 μ s (opentx +100)
 CH3 1000 μ s (opentx -100), CH4 1000 μ s (opentx -100)

Chapter 8 Servo Phase

Please refer to D460 RTF Chapter 8 Servo Phase.

Chapter 9 Three Flight Modes

Please refer to D460 RTF Chapter 9 Three Flight Modes.

Chapter 10 Gyro Sensitivity

Please refer to D460 RTF Chapter 10 Gyro Sensitivity.

Technical Support Here



Contact RadioLink RL
via Facebook Messenger



D460 User Manual



D460 Tutorials

If the above information cannot solve your problem, you can also send emails to our technical support:
after_service@radiolink.com.cn

This content is subject to change. Download the latest manual of D460 from
https://www.radiolink.com/D460_manual

Thank you again for choosing RadioLink product.