

Byme-D

Flight Controller of Delta Wing **Instruction Manual**

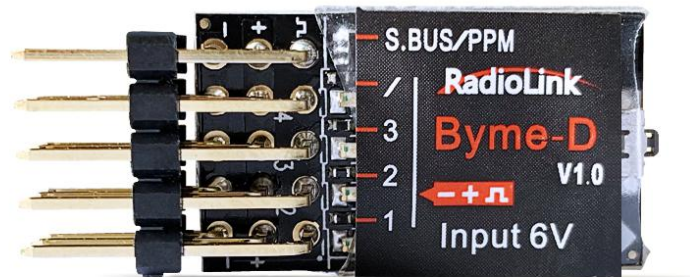

Contents

Safety Precautions-----	3
Introduction-----	4
About Byme-D-----	4
Parameters-----	5
Installation-----	5
Transmitter Setup-----	6
Power-On Calibration-----	7
Attitude Calibration-----	7
Servo Phase-----	8
Flight Modes-----	9
Stabilize Mode-----	9
Gyro Mode-----	10
Manual Mode-----	11
Motor Safety Lock-----	11
Gyro Sensitivity-----	12

Safety Precautions

- Never operate model during adverse weather conditions. Poor visibility can cause disorientation and loss of control of pilots' model.
- Never use this product in a crowd and illegal area.
- Do not install propellers on the aircraft during installation and testing.

Thanks for purchasing RadioLink flight controller Byme-D.

To fully enjoy the benefits of this product and ensure safety, please read the introduction carefully and set up the device as described below. If any problems found during the operation process, please kindly refer to the manual first or send questions to after_service@radiolink.com.cn and we will answer your question at the earliest. Due to unforeseen changes in production procedures, the information contained in this manual is subject to change without notice.

For more information, please check our website <http://www.radiolink.com> and follow our Facebook and YouTube homepage.

WARNING: This product is not a toy and is **NOT** suitable for children under the age of 18. Adults should keep the product out of the reach of children and exercise caution when operating this product in the presence of children.

Introduction

About Byme-D

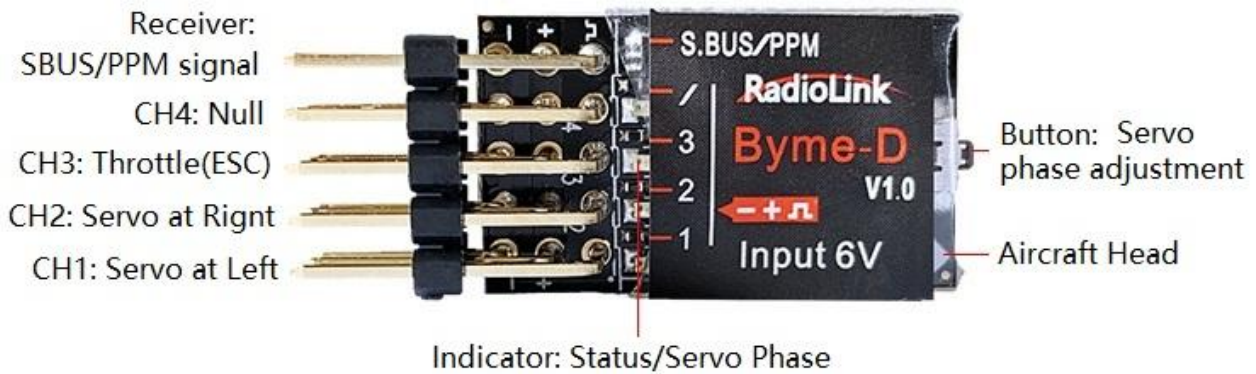

Byme-D is applicable to all model airplanes with mix elevator/aileron controls including delta wing, paper plane, SU27, F22 and is SBUS and PPM signal supported. There are three flight modes: Stabilize Mode, Acrobat Mode and Manual Mode.



Parameters

Size : 35.5*15.5*10.5mm (1.4"*0.61"*0.41")

Weight(With wires) : 4.5g (0.16oz)

Channel Quantity : 3

Integrated Sensor : three-axis gyroscope and three-axis acceleration sensor

Signal Supported : SBUS/PPM

Input Voltage : 5-6V

Operating Current : 25±2mA

Installation

Make sure the servo phase adjustment button on Byme-D points to the aircraft head, and the pin end of Byme-D points to the tail of the aircraft. The flight controller can be installed either face up or down with 3M glue on the aircraft body and the wires connect to the corresponding pins. It is recommended to install Byme-D near the center of gravity (of the aircraft). Please install Byme-D as shown below. (Note: Wrong installation direction and position of Byme-D will lead to inaccurate correction of the flight controller, and it is difficult to achieve the best flight effect).

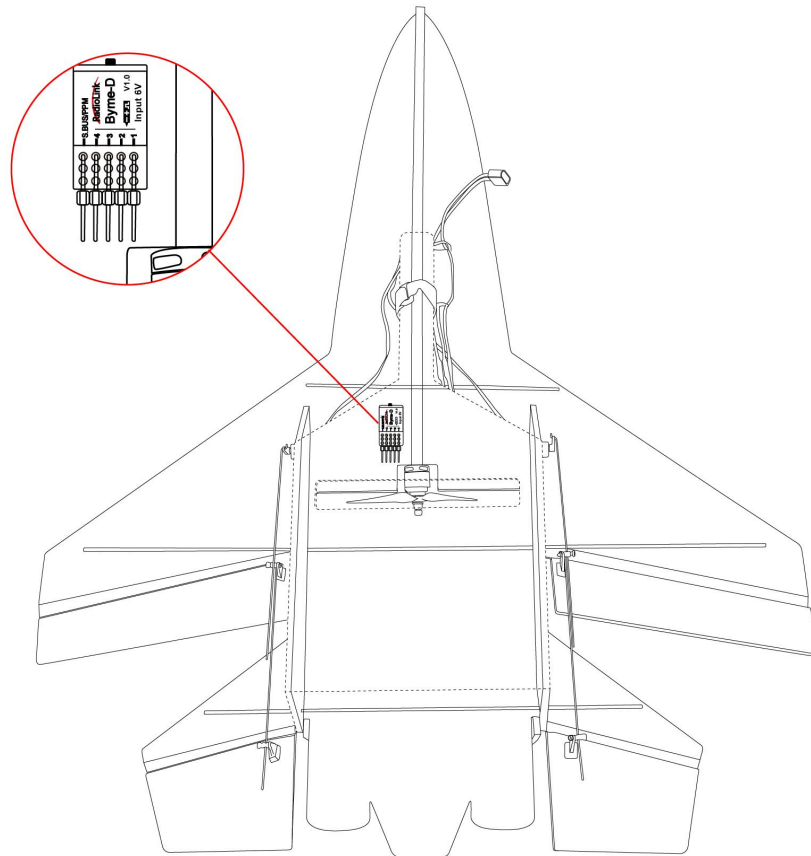

Transmitter Setup

1. Channel 5 (three-way switch) is used to switch among 3 flight modes, and channel 7 is used to lock/unlock the motor. Therefore, only transmitter with 7 channels or more is available.
2. You cannot set any mixing function in the transmitter when Byme-D is mounted on the aircraft. Because there is already the mixing function in Byme-D. The mix control will automatically take effects according to the flight mode of the aircraft. If the mixing function is set in the transmitter, there will be conflicts of mixing function and then affect the flight.
3. Set the direction of the channel as below:
CH3 - Throttle: Reversed
Other channels: Normal

Power-On Calibration

When the aircraft is powered on, the gyro on Byme-D will calibrate with the green led flashing. Please keep the aircraft remain still until the green light is always on.

Attitude Calibration

The flight controller needs to calibrate the attitudes/level to ensure the balanced status. It is advised to lift the model head with a certain angle to ensure the calibration accuracy.

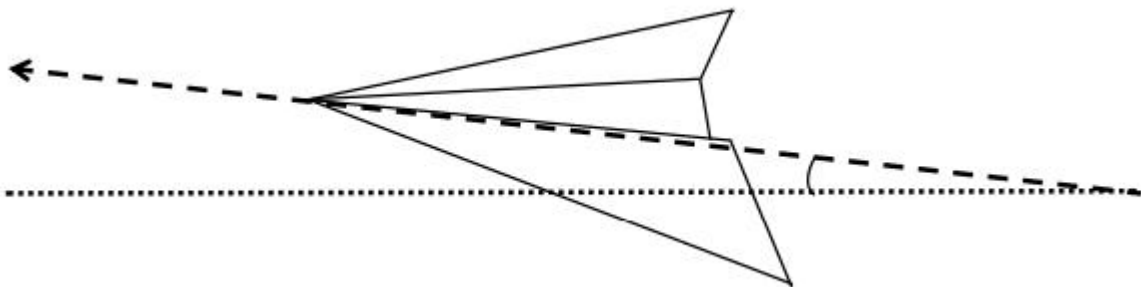

Push the left stick (left and down) and the right stick (right and down) as below and hold more than 3 seconds. The green led flashes once mean the calibration completed.



Note: If you set the direction of the channel as above(CH3 - Throttle: Reversed, Other channels: Normal), but the attitude calibration cannot be finished by pushing the left stick (left and down) and the right stick (right and down), please enter the menu of the transmitter to set the direction of the channel. The direction of the throttle channel still remains reversed. But for other channels, please try the following 3 combinations to set the channel direction and then calibrate the attitude by pushing the left stick (left and down) and the right stick (right and down):

Combination 1: Channel 1- Normal, Channel 2- Reversed

Combination 2: Channel 1- Reversed, Channel 2- Normal

Combination 3: Channel 1- Reversed, Channel 2- Reversed

When the attitude calibration can be done by pushing the left stick (left and down) and the right stick (right and down) with any one of the above combinations of the channel direction, save it and do not make any modifications. After the attitude calibration is finished, please check the servo direction next.

Servo Phase

Make sure the servo phases are correct before flight. Take Manual Mode and Mode 2 as example. (Please refer to Flight Mode in the manual for mode switching)

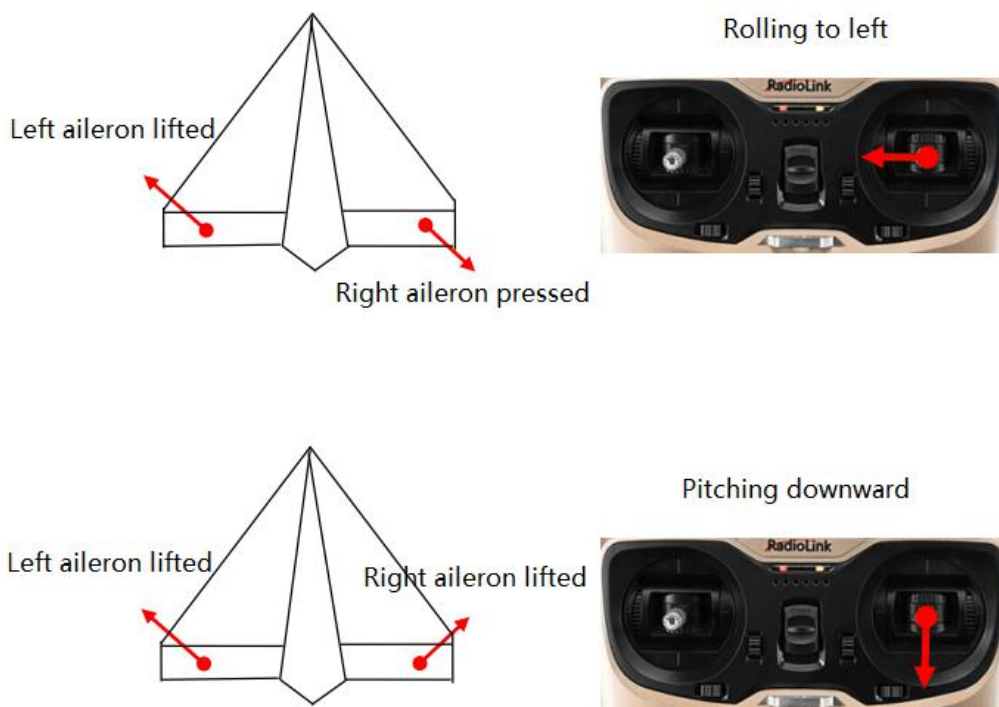

When the movement direction of the aileron is inconsistent with the joystick, please adjust the servo phase through the buttons on the front of Byme-D. Please do not change any settings of servo direction on the remote control at this time.

Press the button at the front of Byme-D to change the servo phase:

Short press once, aileron mix control reversed, LED1 ON/OFF.

Short press twice, elevator mix control reversed, LED2 ON/OFF.

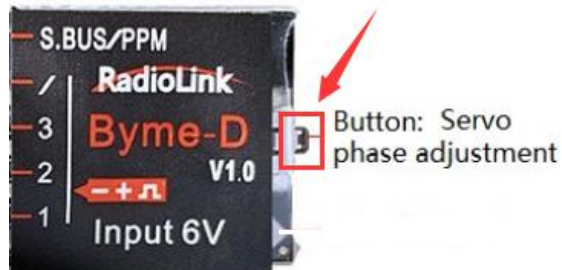

Note: Make sure attitude calibration is complete before changing the servo phases. Byme-D will identify the installation position (above/bottom of the aircraft) to automatically adjust the gyro direction.

Flight Modes

Flight modes can be set by CH5 (3-way switch) on transmitter.

There are three modes: Stabilize, Gyro and Manual.

Stabilize Mode

The model attitude (inclination angles) is controlled by joysticks.

The max inclination angle is 70° for rolling while that for pitching is 45°.

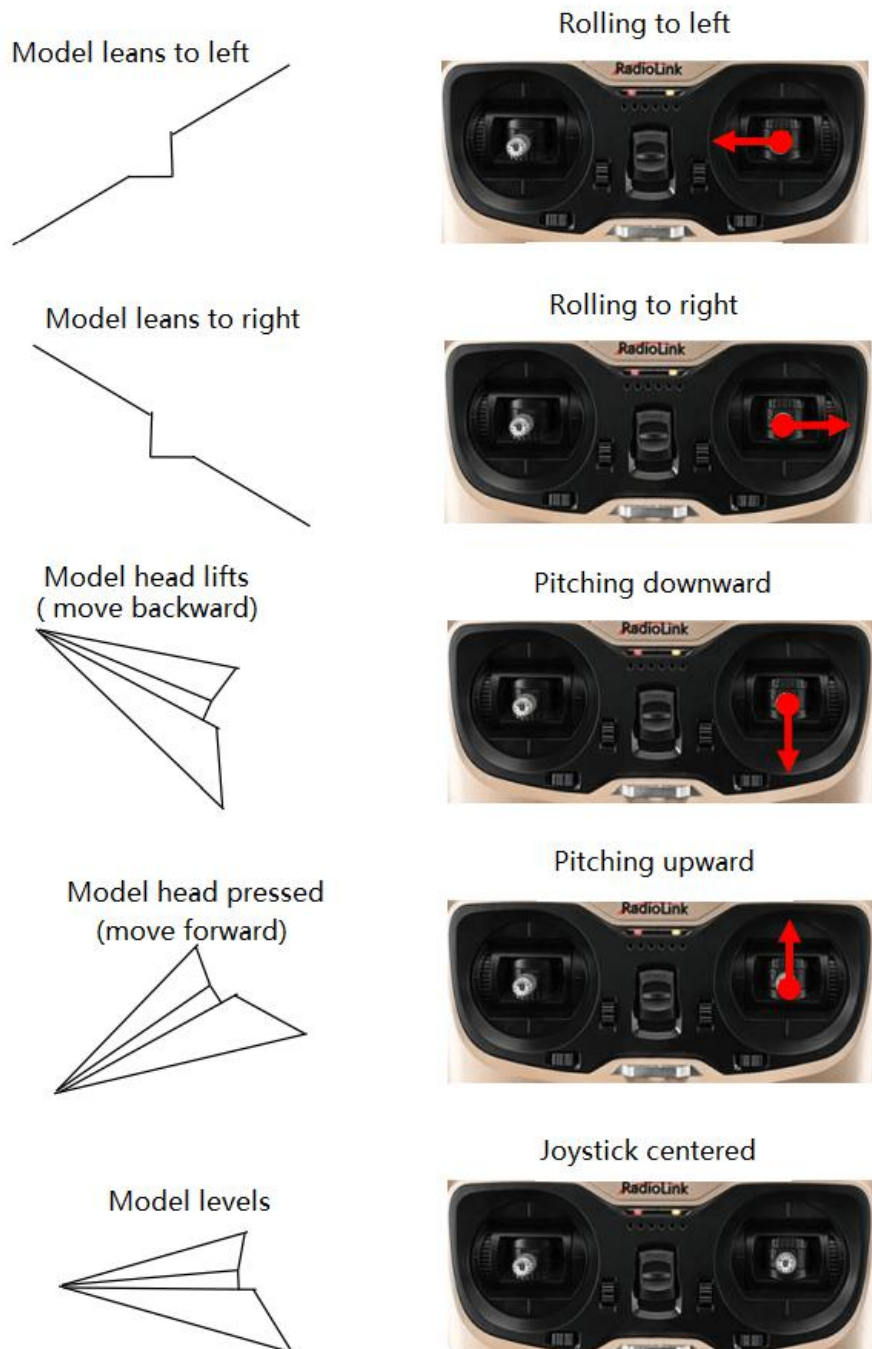

Gyro Mode

The model rotation is controlled by joysticks with gyro increasing the stability. This is an advanced mode. The model won't level but and keeps rotating when joystick is loose.

Models rotates horizontally

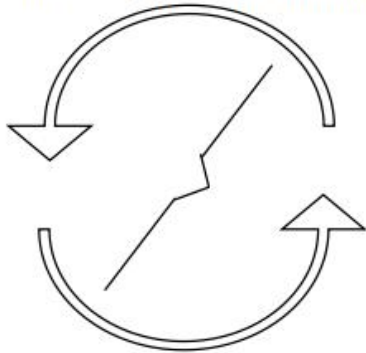

Rolling to left



Models rotates vertically

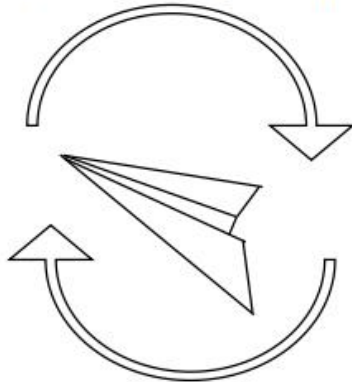

Pitching downward



Manual Mode

Pilots control servos with corresponding channels by transmitter, neither attitude nor gyro involved.

Motor Safety Lock

The lock can be turned on/off by CH7 (2-way switch) of the transmitter.

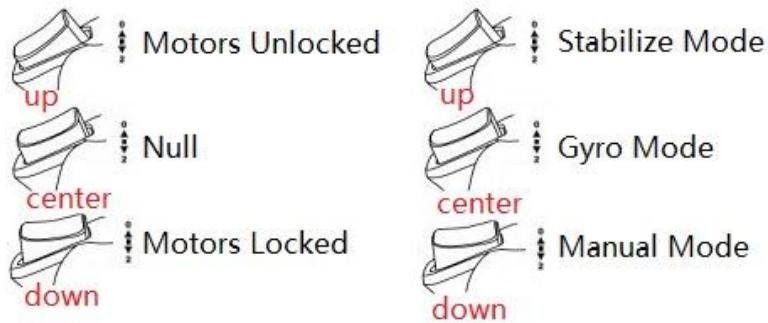
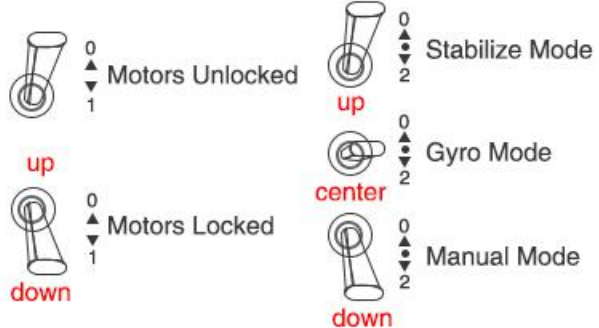

Gyro Sensitivity

There is certain stability margin for the Byme-D PID control. To different models, if Byme-D under correct or over correct, pilots can try adjusting the rudder angle.