

# BYME-D

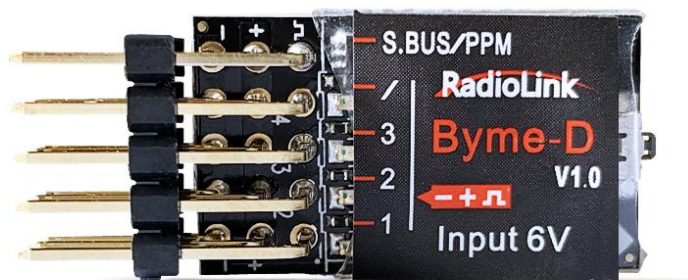

## Flight Controller Of Delta Wing Instruction Manual

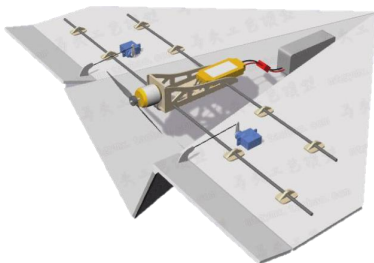

Thanks for purchasing Radiolink flight controller Byme-D .

To fully enjoy the benefits of this product and ensure safety, please read the introduction carefully and set up the device as described below:

If any problems found during the operation process, please kindly refer to the manual first.

Then pilots could contact our distributors to find solution or follow our Facebook homepage

<https://www.facebook.com/Radiolink-1455452961436694/> to search related key words. Also

pilots can send questions to [after\\_service@radiolink.com.cn](mailto:after_service@radiolink.com.cn) or

[after\\_service1@radiolink.com.cn](mailto:after_service1@radiolink.com.cn) and we will answer your question at the earliest.

Due to unforeseen changes in production procedures, the information contained in this manual is subject to change without notice.

For more information please check our website <http://www.radiolink.com> and follow our Facebook and Youtube homepage.

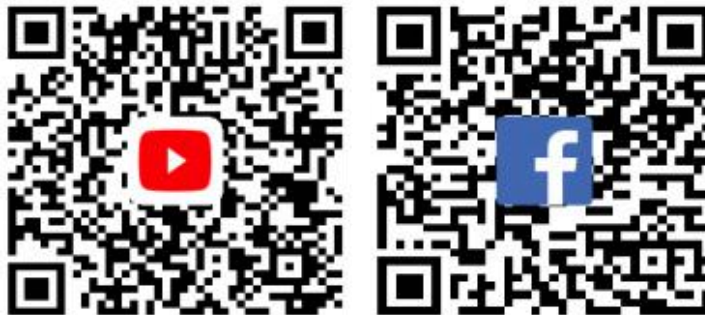

### SAFETY PRECAUTIONS

- Never operate model during adverse weather conditions. Poor visibility can cause disorientation and loss of control of pilots' model.
- Never use this product in a crowd and illegal area.
- Always ensure the trim levers at 0 and battery properly charged before connecting the receiver.
- Always check all servos and their connections prior to each run.
- Always be sure about turning off the receiver before the transmitter.
- To ensure the best radio communication, please enjoy the flight/driving at the space without interference such as high voltage cable, communication base station or launching tower.

### WARNING

This product is not a toy and is **NOT** suitable for children under the age of 18. Adults should keep the product out of the reach of children and exercise caution when operating this product in the presence of children.

Water or moisture may enter the transmitter inside through gaps in the antenna or joystick and cause model instability, even out of control. If running in the wet weather (such as game) is inevitable, always use plastic bags or waterproof cloth to cover the transmitter.

## 1. Introduction

Byme-D is applicable to all model airplanes with mix elevator/aileron controls including delta wing, paper plane, SU27,F22 and is SBUS and PPM signal supported

There are three flight modes: Stabilize Mode, Gyro Mode and Manual Mode.

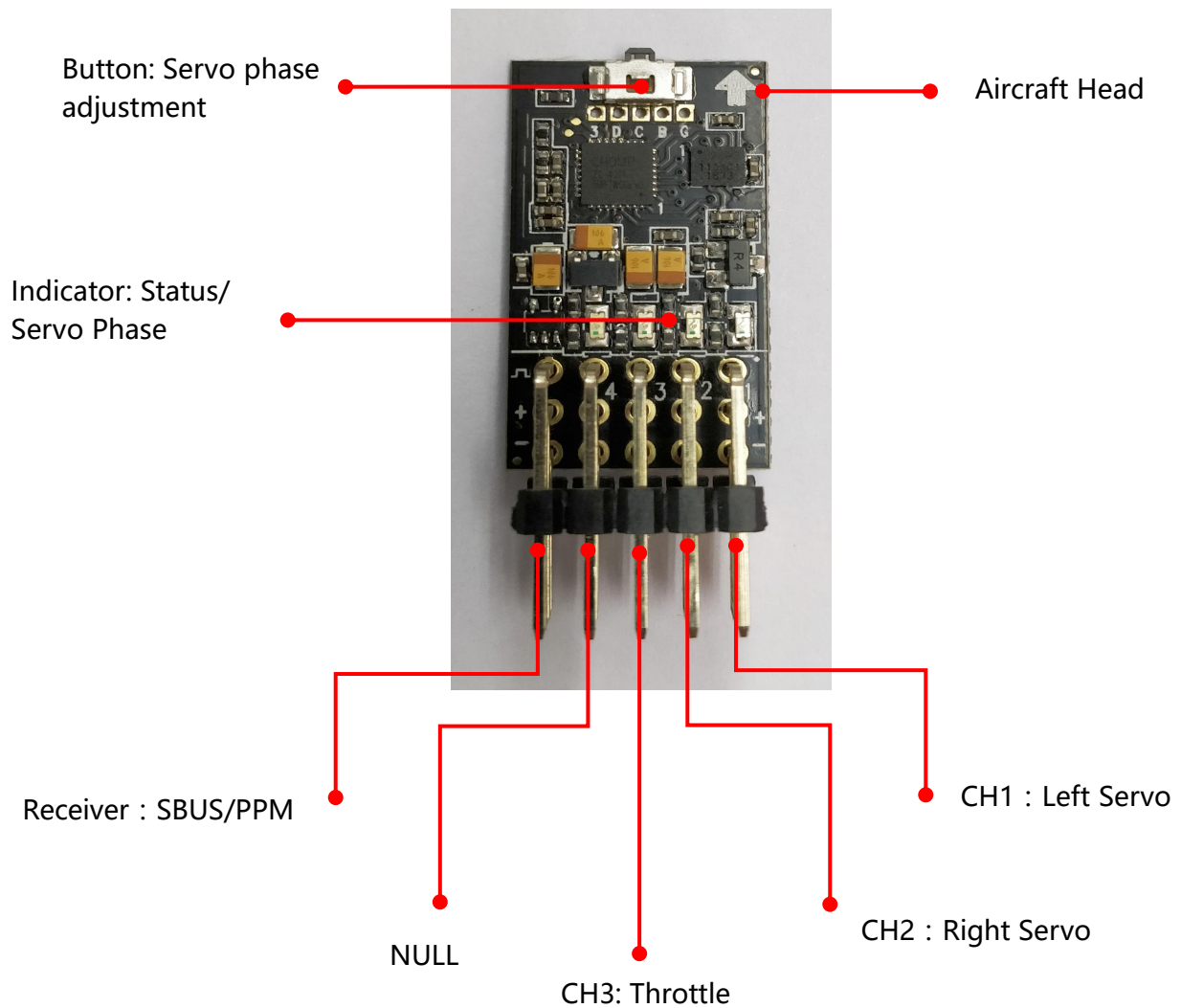

## 2. Parameters

Input Voltage : DC 5V ( Max. 6V )

Pin : 2.54mm \* 3 pin \* 5

Weight: 2.5g (with pins)

Dimension: 35\*14.65mm

## 3. Installation

Make sure the arrow on Byme-D points to the aircraft head. The flight controller can be installed either face up or down with 3M glue on the aircraft body and the wires connect to the corresponding pins.

## 4. Flight Modes Setup

Flight modes can be set by CH5 (3-way switch) on transmitter.

There are three modes: Stabilize, Gyro and Manual.

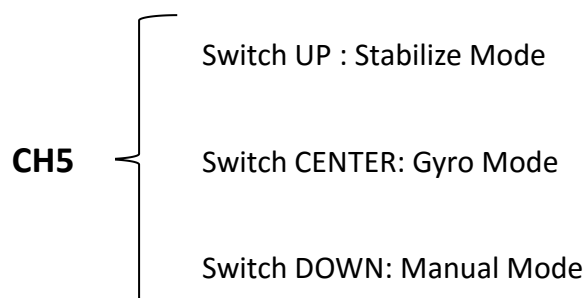

## 5. Motor Safety Lock

The lock can be turned on/off by CH7 (2-way switch) of the transmitter.

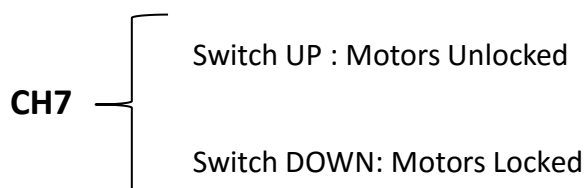

## 6. Transmitter Phase Setup

CH3 - Throttle: Reversed

Other channels: Normal

## 7. Power-On Calibration

When the aircraft is powered on, the gyro on Byme-D will calibrate with the green led flashing. Please keep the aircraft remain still until the green light is always on.

## 8. Attitude Calibration

The flight controller needs to calibrate the attitudes/level to ensure the balanced status.

It is advised to lift up the model head with a certain angle to ensure the calibration accuracy.

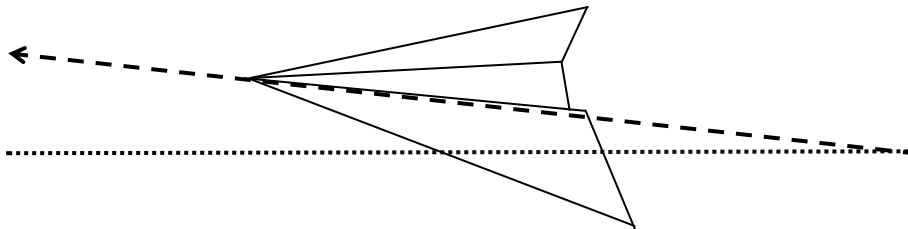

Pull both joysticks to outside corners as below and hold more than 3 seconds. The green led flashes once means the calibration completed.



## 9. Servo Phase

Make sure the servo phases are correct before flight.

Take Manual Mode and Mode 2 as example.

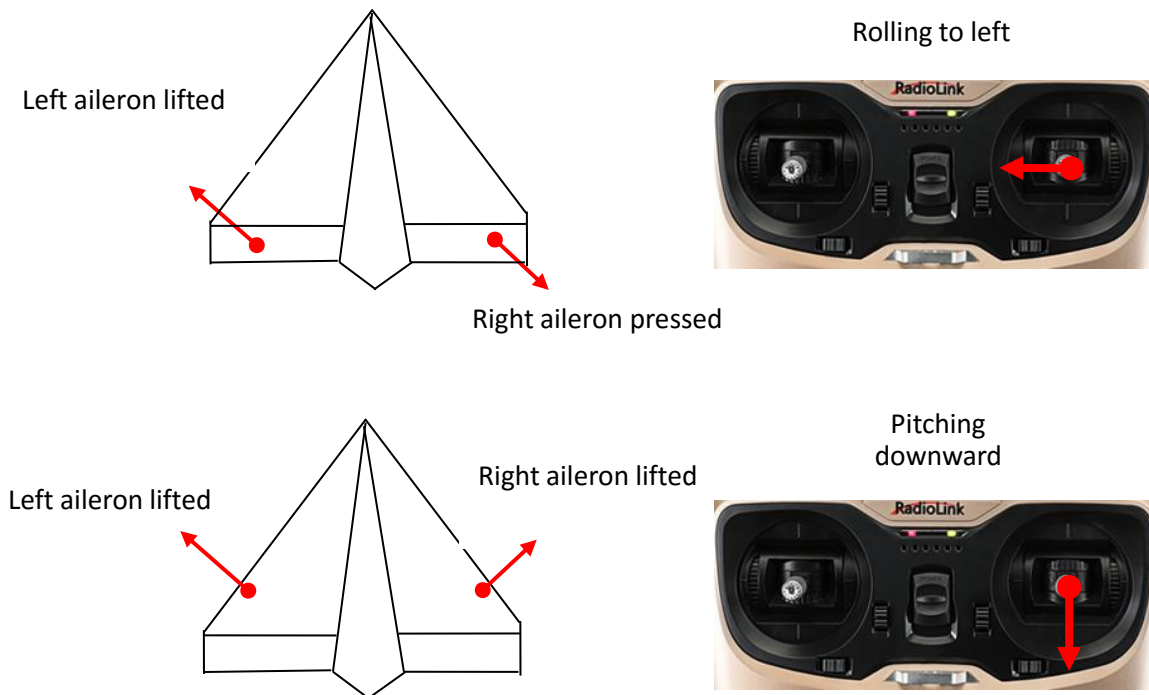

## 10. Output Servo Phase Adjustment

Press the button at the front of Byme-D to change the servo phase:

Short press once, aileron mix control reversed, LED1 ON/OFF.

Short press twice, elevator mix control reversed, LED2 ON/OFF.

Note: Make sure attitude calibration is complete before changing the servo phases. Byme-D will identify the installation position (above/bottom of the aircraft) to automatically adjust the gyro direction.

## 11. Flight Modes

### ① Stabilize Mode

The model attitude (inclination angles) is controlled by joysticks.

The max inclination angle is  $70^\circ$  for rolling while that for pitching is  $45^\circ$ .

Model leans to left

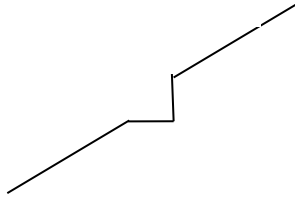

Rolling to left



Model leans to right

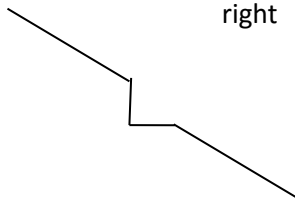

Rolling to right

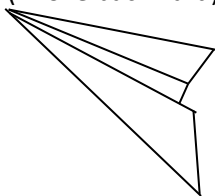
Model head lifts  
(move backward)

Pitching downward

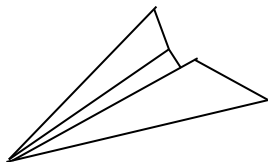
Model head pressed  
(move forward)

Pitching upward



Model levels

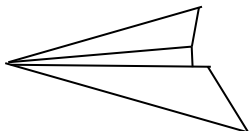

Joystick centered



## ② Gyro Mode

The model rotation is controlled by joysticks with gyro increasing the stability. This is an advanced mode. The model won't level but and keeps

rotating when joystick is loose .

Models rotates horizontally

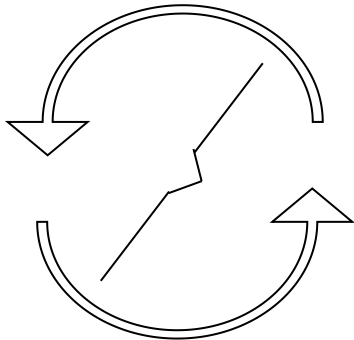

Rolling to left



Models rotates vertically

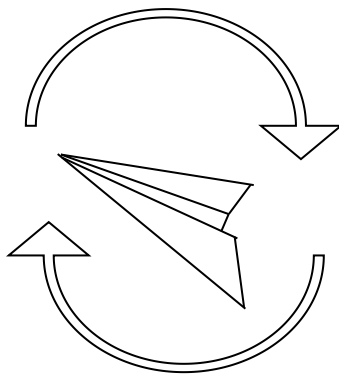

Pitching downward



### ③ Manual Mode

Pilots control servos with corresponding channels by transmitter, neither attitude nor gyro involved.

## 12. Gyro Sensitivity

There is certain stability margin for the Byme-D PID control. To different models, if Byme-D under correct or over correct, pilots can try adjusting the rudder angle.

**Thank you again for choosing Radiolink product**